

AERATION TREATMENT OF ONSITE DOMESTIC WASTEWATER AEROBIC UNITS AND PACKED BED FILTERS

James C. Converse¹

January, 1997

Revised, January 1999

Revised, February 2000

Revised, August 2001

On-site waste treatment and management utilizes anaerobic and/or aerobic processes for the treatment of domestic waste. A number of units are commercially available and can be categorized as either **aerobic units (ATUs) or packed bed filters (PBFs)**. Aerobic units are submerged units in which air (oxygen) is introduced into the mixed liquor with oxygen diffusing into the liquid. Pumps and blowers provide the air. Packed bed filters are unsaturated units in which the air diffuses in and through the voids created between the media. Air diffuses in from the atmosphere. Some units will have a small fan to increase circulation of the air.

This publication is divided into two main categories: aerobic units and packed bed filters. All units approved in Wisconsin as of January, 2000 will be described. It will also contain other units. **This presentation is not inclusive and does not imply endorsement of one product over another and it will continually be updated to include more units.**

TESTING PROTOCOL

To establish quality control in aerobic units (ATUs) and protect the public from poor quality and low performance units, NSF, International, in cooperation with the industry and the regulatory community, developed a testing performance standard (Standard Number 40), (NSF, 1996). For a fee, NSF, International will test aeration units using domestic waste under a controlled pilot plant (field) environment measuring influent and effluent quality and performance under various loading regimes. The standard has Class I and Class II levels based on performance standards as follows:

¹ James C. Converse, P.E., Professor, Department of Biological Systems Engineering, College of Agricultural and Life Sciences, University of Wisconsin-Madison. Member of the Small Scale Waste Management Project.

Note: Names of products and equipment mentioned in this publication are for illustrative purposes and do not constitute an endorsement, explicitly or implicitly. It does not include all units available on the market and the presence or absence of a product does not imply acceptance or rejection of a particular product.

Class I Effluent

Plants providing a Class I effluent shall be shown to meet EPA Secondary Treatment Guidelines (Federal Register, 1987) for BOD₅, SS, and pH. These are as follows:

CBOD₅ :

- The 30-day average of CBOD₅ concentration of effluent samples shall not exceed 25 mg/L.
- The 7-day average of CBOD₅ concentration of effluent samples shall not exceed 40 mg/L

TSS:

- The 30-day average of TSS concentrations of effluent samples shall not exceed 30 mg/L.
- The 7-day average of TSS concentrations of effluent samples shall not exceed 45 mg/L.

pH:

- The pH of individual effluent samples shall be between 6.0 and 9.0.

Other:

- Color - 15 units
- Threshold Odor - non-offensive
- Oily Film - nonvisible evidence other than air bubbles
- Foam - None

Class II Effluent

Not more than 10% of the effluent CBOD₅ values shall exceed 60 mg/L. Not more than 10% of the effluent TSS values shall exceed 100 mg/L.

As noted, NSF, International primarily evaluates a unit for BOD and suspended solids effluent concentration. With the increased interest in nitrogen removal and pathogen removal, all aeration units should be evaluated for nitrogen and pathogen removal. For soil based treatment/dispersal, pathogen and nitrogen removal are as important if not more important than BOD and suspended solids removal. BOD and suspended solids removal have been and will continue

to be important parameters, especially for surface water discharge and are used by the industry for secondary treatment performance. **Phosphorus and virus removal are also important emerging concerns.** To date no packed bed filters have been NSF tested. The fact that they have not been NSF tested should not imply that they are inferior or incapable of receiving NSF classification. In fact some aerobic units have not been NSF rated. Many reasons may dictate why a company has not had their unit evaluated. **Standard 40 was developed to evaluate aerobic units (ATUs).** Since then a number of packed bed units have emerged.

AEROBIC UNITS (ATUs)

Aeration technology, known as activated sludge, extended aeration and similar other names, is used extensively in large municipal systems for treating wastewater. Industry has developed “miniature” plants adapted for small clusters and for individual home use. This discussion will be limited to the concepts and performance of small units known as individual home wastewater treatment plants, aerobic units or ATUs and other units that utilize aeration for treating the wastewater that come as “prepackaged units”. **These units can be categorized as either: 1) suspended growth , 2) attached growth (submerged fixed media) or 3) combination of both. Aeration is achieved by mechanically delivering air bubbles to a liquid (water) media where the oxygen diffuses into the liquid so it can be utilized by the bacteria.**

ATUs have been marketed for many years in some parts of the country but are now being introduced in other parts of the country. Many improvements have been and are continuing to be made and new systems are being introduced.

System Characteristics

- Systems can be either batch or flow-through (known as intermittent flow).
- Most systems have a septic tank/trash tank, external or internal, to settle out the large solids and scum. Some systems may pump the effluent from the septic tank to the aerobic unit utilizing a timer for more uniform loading. The septic tank must be water tight.
- All system have a method of incorporating air into the wastewater to maintain dissolved oxygen in the wastewater either continuously or intermittently.
- All systems incorporate some method of solids separation such as settling, filtering through a fabric or through a plate filter.
- All systems require sludge removal or destruction.
- Systems operate in an extended aeration mode to reduce solids accumulation except for

periods when they are loaded heavily.

- Most units are quite sensitive and can be easily upset by the addition of toxic chemicals and some medications. Rapid and large changes in organic and hydraulic loading can upset these units. During these times the units may foam and froth with increased BOD and SS effluent concentrations. Seeding the unit at start-up and after upsets will usually bring the system to stability earlier.
- Excess solids may on occasion exit the unit either around the cover or through the effluent pipe (bulking) depending on system configuration. Bulking takes place when the solids do not settle out and as a result exit the unit through the outlet pipe.
- All systems have sensors and high water alarms to alert the owner to problems.
- Most units state power rating in horsepower or amps and volts and state the cfm and pounds of BOD₅/day that the unit is capable of processing. They also state flow rate in gpd they are capable of handling.
- All systems require periodic maintenance by a professional at 6 month intervals. Telemetry may reduce the frequency of site visits.

Suspended-growth Units

In suspended growth systems, microorganisms are kept in suspension in an aeration tank where air is mixed with the wastewater. The following systems primarily use suspended-growth as the method of converting organic matter into bacterial cells, carbon dioxide and water.

a. Multi-Flo Waste Treatment Unit

The unit is constructed of fiberglass and comes factory assembled (Fig. 1). This unit is NFS Class 1 rated. The unit comes in a variety of sizes with the smallest unit of 500 gallons capable of treating the effluent from a 3 bedroom home. Larger units, up to 1500 gallons, are available.

A trash tank, proceeding the unit, may or may not be recommended for removal of settleable solids. The wastewater (or trash tank effluent) enters the inlet and drops into the basin (activated sludge or mixed liquor portion). Flow is by gravity. Some systems are installed with a pump located in the trash tank with a timer which doses a small amount of wastewater frequently during the day to provide a more uniform flow into the unit (Fig. 2). Surge capacity is designed into the trash tank. Small, frequent doses are desired.

An aerator, located in the bottom of the tank, pulls in air and disperses fine bubbles which work their way to the top with oxygen dissolving into the effluent.

As wastewater enters, an equal amount of effluent moves through the filter fabric, upward inside the filters (cylinder) and over the weir, exiting through the outlet. The filter fabric retains the solids (primarily bacterial cells) within the basin. The filter surface acts as a fixed media for bacteria growth. The surge bowl allows for some foaming and surge capacity. Liquid sensors are located to detect high water and pump failure.

This unit removes some nitrogen but it does not incorporate a discrete nitrification/denitrification phase as part of the treatment process. Access to the unit is through the cover

and
liftin
g
out
the
sur
ge
bo
wl.

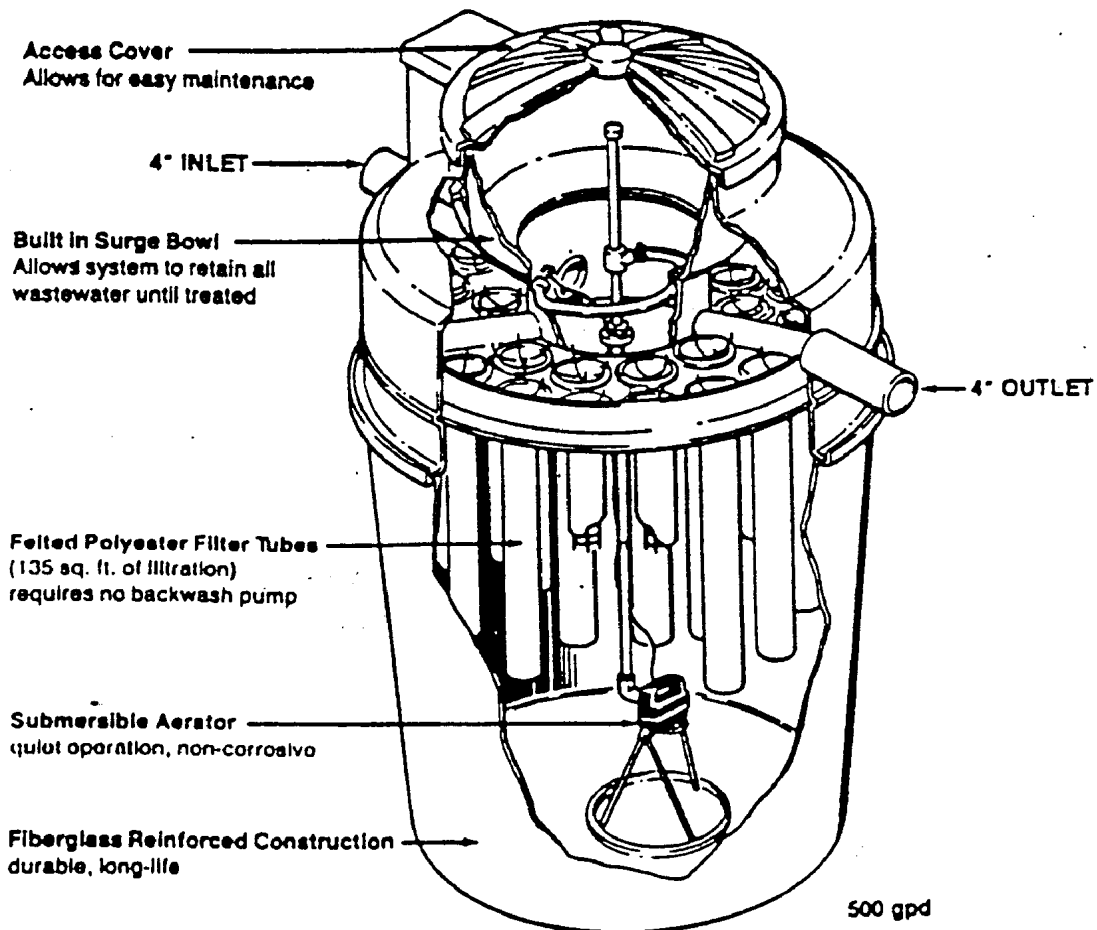

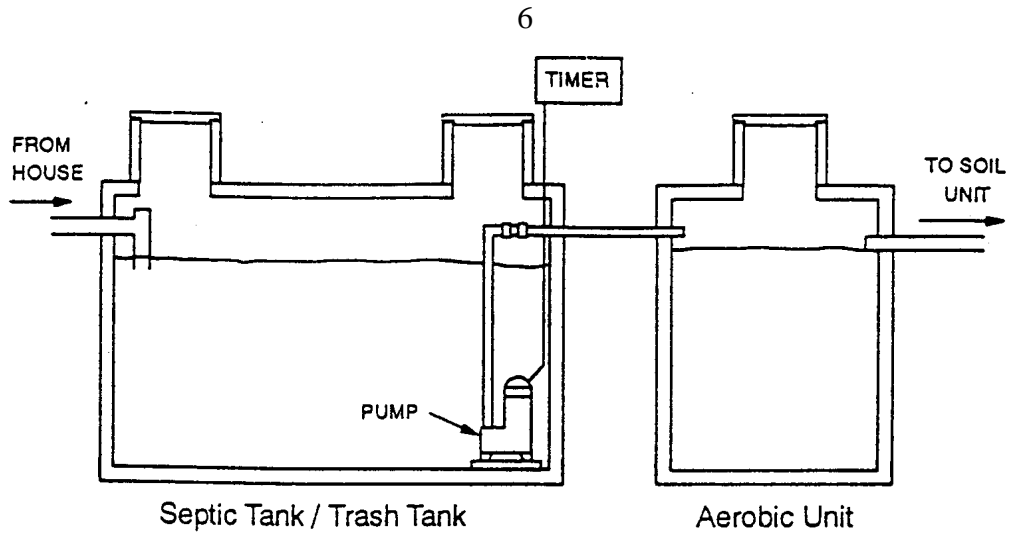

Fig. 1.
A cut-

away view of the Multi-Flo unit. (Consolidated)

Fig. 2. Illustration of a trash/septic tank with pump and timer pumping effluent to the aeration unit minimizing surge flow.

b. Norweco Singlair Wastewater Treatment Plant

The unit consists of a concrete tank divided into 3 compartments (Fig. 3). The tanks are locally manufactured and outfitted with factory-made pumps, filters and controls. This unit is NSF Class 1 rated. The unit comes in several sizes with the smallest being a 500 gpd unit serving a 3 bedroom home.

The wastewater from the home enters a pretreatment chamber where the larger solids settle out. The liquid volume of the pretreatment chamber is approximately 440 gallons in the 500 gpd unit.

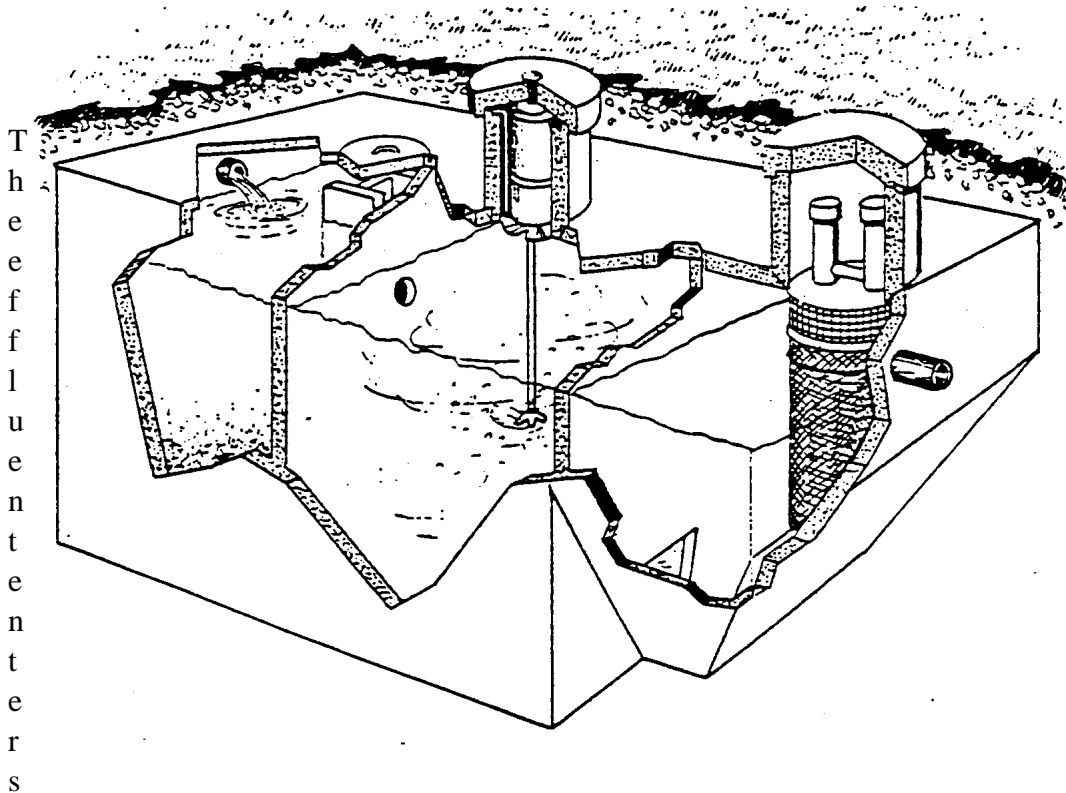

T
h
e
e
f
f
l
u
e
n
t
e
n
t
e
r
s

the extended aeration chamber through a submerged port where the suspended and dissolved solids are converted to bacterial cells, water and carbon dioxide. The contents of this chamber are typically called mixed liquor. The liquid volume of this chamber is 590 gallons for the 500 gpd unit.

A top-mounted motor rotates a shaft with a hub with several openings. Air is drawn through the hollow shaft and through the holes in the hub with bubbles dispersing into the mixed liquor. The rotating hub and air bubbles keep the contents mixed. Oxygen is diffused into the mixed liquor as the air bubbles move in the liquid.

Mixed liquor moves to the clarifier through a port located in the bottom of the unit. The solids settle to the bottom of the clarifier. The sloping walls of the clarifier assists the movement of solids back into the aeration chamber.

Fig. 3. Cut-away view of the Norweco Singulair unit (Norweco).

The effluent moves into the Bio-Kinetic filter unit which consists of a series of plates that promote quiescent settling. The remaining solids settle out and a relatively clear effluent exits the tank through the outlet. This unit removes some nitrogen but it does not incorporate a discrete nitrification/ denitrification phase as part of the treatment process.

Access to the system is through the inspection port (pretreatment chamber), the aerator port (aerator lifts out) and the Bio-Kinetic port (clarifier).

c. **Cromoglass**

The unit consists of a 3 compartment fiberglass tank (Fig. 4). This unit is classified as a sequence batch reactor (SBR) as it is a fill and draw (batch) unit. It comes in several sizes with the smallest unit serving a 3 bedroom home.

The wastewater from the home enters the solids retention section where the large solids settle out. Effluent enters the aeration chamber through a screen located in the wall, near the bottom, dividing the solids retention and aeration chamber.

The pump in the aeration section circulates mixed liquor in the aeration chamber and forces mixed liquor through the screen into the solids retention section breaking up the solids and also pumps it into the contact clarifier. The mixed liquor flows back into the aeration chamber via an opening in the wall near the top.

As the pump moves mixed liquor through the overhead pipe, air is pulled in through the air intake allowing oxygen to dissolve into the mixed liquor. The pump operates continuously mixing and aerating the mixed liquor.

At a preset time or when the mixed liquor reaches a certain level, the pump shuts off allowing

the solids to settle in the clarifier for a 60 minute period. After settling, the effluent is pumped out of the clarifier. The timer is normally set for six aeration/settle/ discharge cycles per day. The discharge pump will not operate when the liquid level in the aeration chamber is below the low water float level. Thus, the number of discharges will depend on the flow to the system.

Some nitrogen is removed during the process. However, a denitrification option is available. This option requires the installation of the next larger size unit, a timer and controls to disengage the circulating pump, stopping aeration. The oxygen is rapidly depleted producing an anoxic condition in the aeration and clarifier sections resulting in the denitrification of the nitrates. After a prescribed time, the timer starts up the pump which provides oxygen to the unit.

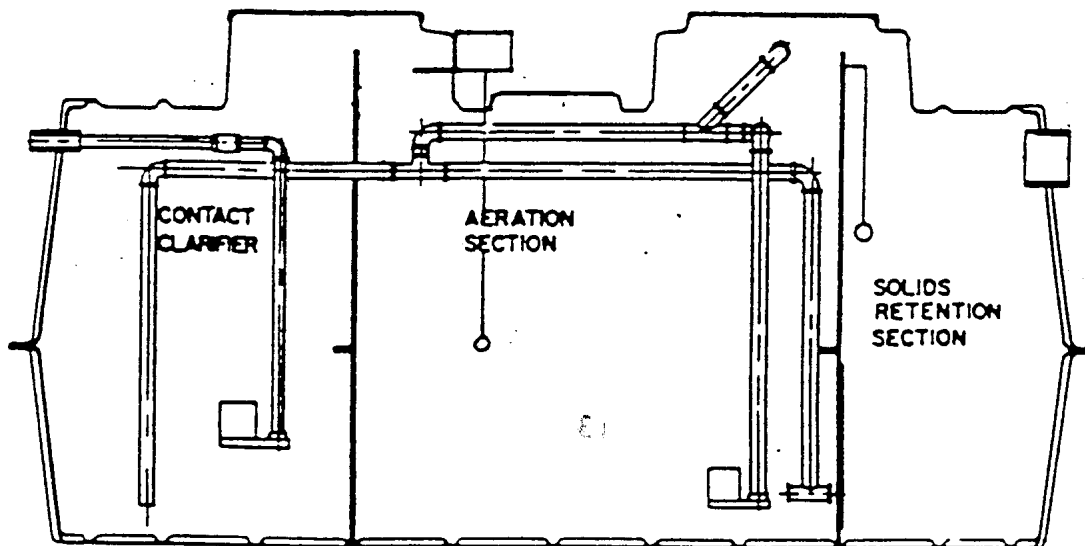

Fig

. 4. Cross section of a Cromoglass unit (Cromoglass).

d. Clearstream Wastewater Unit

The unit consists of a single tank with a Imhoff cone in the center (Fig. 5). Unit sizes range from 500 to 1500 gallon capacity. This unit is NSF Class 1 rated. The household wastewater enters an external trash trap with a volume of 50 to 100% of the gallon per day rating of the Clearstream unit.

A remote blower supplies air to a diffuser located along the outside wall near the bottom of the tank. Influent enters the tank near the outer edge and moves down around the outside of the Imhoff cone where it comes in contact with the mixed liquor. Effluent moves up through the bottom of the Imhoff cone which provides a quiescent settling area for solids to fall back into the mixed liquor portion of the tank.

The effluent exits through a tertiary filter (optional) attached to the outlet pipe. Solids need to be removed from the tank periodically. This unit removes some nitrogen but it does not incorporate a discrete nitrification/ denitrification phase as part of the treatment process.

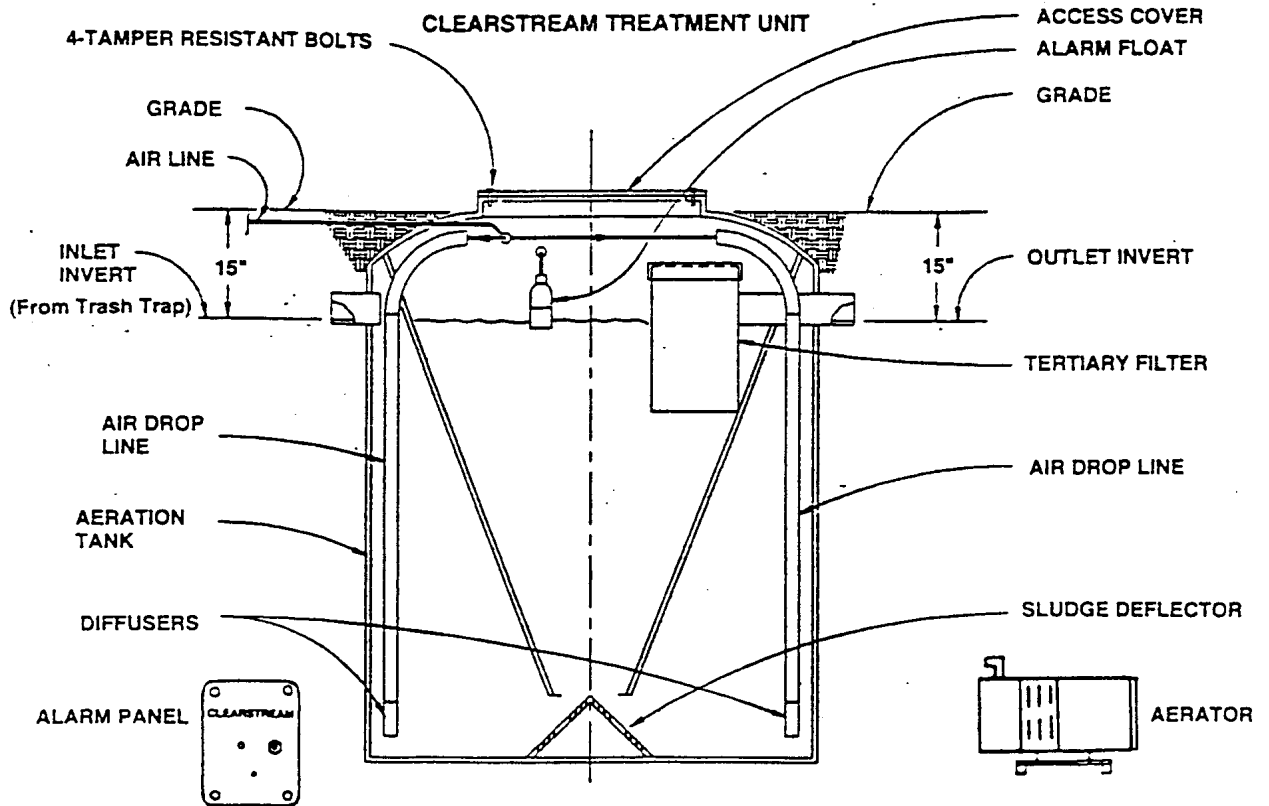

Fig. 5. Cross section of a Clearstream unit (Clearstream).

e. Delta Whitewater

The unit consists of a single tank with a Imhoff cone in the center (Fig. 6) in sizes ranging from 400 gpd to 1500 gpd. This unit is NSF Class 1 rated.

The household wastewater may or may not enter an external trash trap (optional).

A remote blower (65 watts) supplies air to several diffusers located along the outside wall near the bottom of the tank. A minimum of 2100 cf of aeration is provided per each pound of BOD₅. The 400 gpd unit has a treatment capacity of 1.0 lb BOD₅.

Influent enters the tank near the outer edge and moves down around the outside of the Imhoff cone where it comes in contact with the mixed liquor. Effluent moves up through the bottom of the Imhoff cone which provides a quiescent settling area for solids to fall back into the mixed liquor portion of the tank.

The effluent exits through the outlet pipe. Solids are removed from the tank periodically. This unit removes some nitrogen but it does not incorporate a discrete nitrification/ denitrification phase as part of the treatment process.

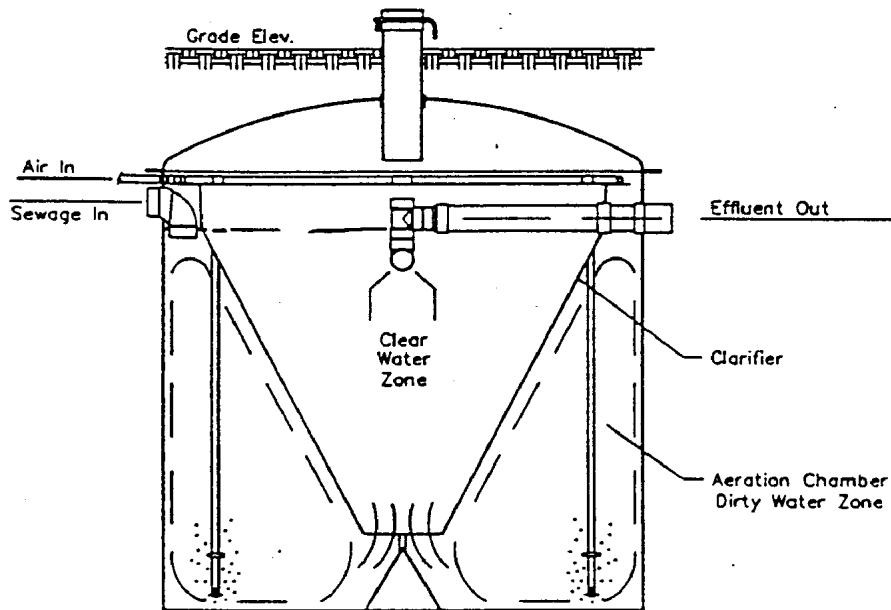

Section

Fig. 6. Cross section of a Delta Whitewater unit (Delta).

f. Nayadic

This unit consists of a two concentric cone shaped tank with one compartment inside the other. Fig. 7 shows a cut-away view of the tank with sizes ranging from 500 to 1500 gpd capacity. This unit is NSF Class I rated.

The tank normally receives effluent directly from the source with a trash tank up front optional. However, for best performance time dosing with small frequent doses is recommended (Fig. 2) with a trash tank serving as a surge tank.

The raw wastewater enters the inner compartment. A blower discharges air to a diffuser in the open bottom of a draft tube in the center of the inner tank. The air lifts the mixed liquor upward with the solids settling down around the outside of the draft tube. The cycle continues with the aeration and mixed liquor confined to the inner tank.

As wastewater enters the tank, effluent from the inner tank moves downward through the solids laden mixed liquor in the bottom and upward in the outer tank. As the effluent rises, the solids settle downward to the center below the draft tube and are drawn up into

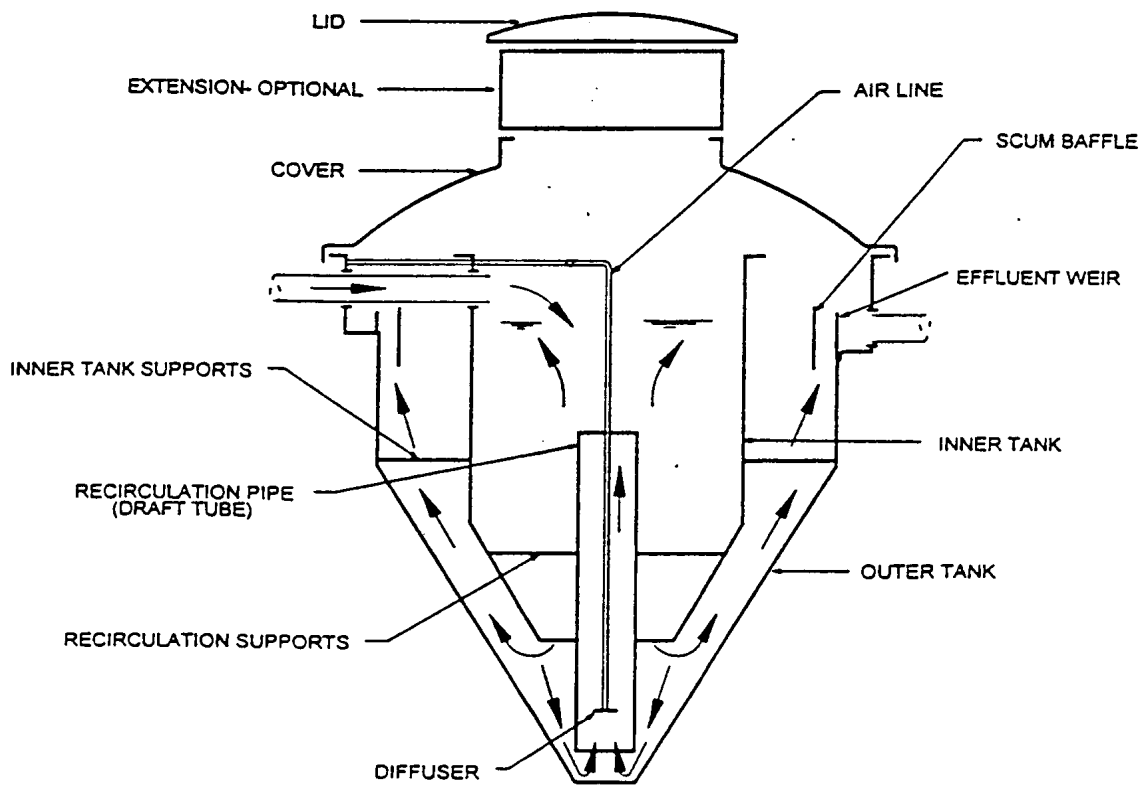

Fig. 7. A cutaway view of the Natick wastewater treatment unit (Consolidated).

the mixed liquor. Clear effluent flows over the 360° weir and out the exit pipe. A scum baffle located inside the overflow weir keeps floating solids from passing over the weir.

This unit removes some nitrogen but it does not incorporate a discrete nitrification/denitrification phase as part of the treatment process. However, as the nitrified effluent moves downward into and through the solids laden bottom where the oxygen levels are probably very limited some nitrogen removal, via nitrification/denitrification, takes place.

Attached-growth Units

Attached-growth aerobic units incorporate a large surface area for bacteria to attach themselves. These surface areas may be fixed or they may be floating cylinders/spheres that move around in the mixed liquor.

a. Jet Treatment Plant

The J-353 model contains the “Jet Bat Process Media” in the aeration section (Fig. 8). This unit is primarily a submerged attached-growth media unit with the lower portion operating as suspended-growth phase. This unit is NSF Class 1 rated. It comes in several sizes.

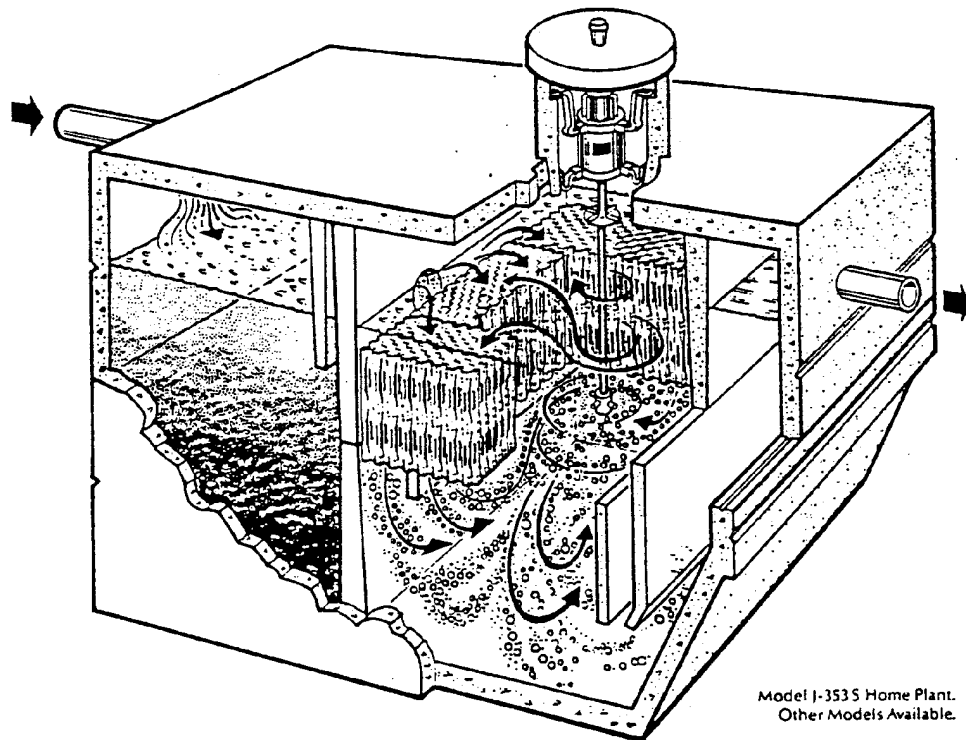

Fig. 8. A cut-away view of the J-353 Model Jet aeration plant for home use (Jet).

The wastewater from the home enters the pretreatment tank where the solids settle out. The chamber is sized at 475 gallons for a 3 bedroom size home. The effluent enters the extended aeration chamber through a submerged port where the suspended and dissolved solids are converted to bacterial cells, water and carbon dioxide. This compartment is sized at 600 gallons. Bacteria are attached to the fixed media in the upper portion of the compartment.

A top mounted motor rotates a shaft with a hub containing several openings. Air is drawn through the hollow shaft and through the hub with bubbles dispersing into the mixed liquor surrounding the shaft. Oxygen is diffused into the mixed liquor as the air bubbles move in the liquid. The rotating hub and air bubbles circulates mixed liquor throughout the fixed media. The mixed liquor moves through the porous media supplying dissolved oxygen and food (Fig. 8). Solids slough off the fixed media settling to the bottom of the compartment.

The mixed liquor moves out the bottom of the aeration chamber into and up through the clarifier section where the solids settle out. Some of the solids move back into the aeration chamber with the assistance of the sloping wall. This compartment is sized at 125 gallons. An optional tube settler is available for this compartment. The effluent flows out through the outlet pipe.

b. Bio-Microbics - FAST

This unit consists of a two compartment tank (Fig. 9). The tanks are locally manufactured and outfitted with a media chamber, external blower and controls. It has a NSF Class 1 rating.

Solids settle out in the first compartment with effluent flowing into the second compartment through a hole located near the top of the wall.

The FAST media chamber, inserted into the top of the second compartment, provides large surface area for bacteria attachment. The bottom of the chamber is open. An air lift tube (tube within a tube) is located in the center of the fixed media. Air, from an external blower is forced downward in the inner tube. As it exits the inner tube, it flows upward between the larger and smaller tubes. The air bubbles lift mixed liquor upward dispersing it over the top of the media where the mixed liquor and dissolved oxygen move downward through the media. Bacteria extract the organic matter, converting it to carbon dioxide, water and new cells. Organic nitrogen and ammonia are converted to nitrates. Solids slough off the fixed media and accumulate in the bottom portion of the second chamber.

A small trough located on top of the media (not shown) diverts some of the mixed liquor through the chamber sidewall into the second compartment outside the aeration chamber, where anoxic conditions exist. The nitrate is denitrified to nitrogen gas.

As wastewater moves into the second compartment, liquid moves out the discharge pipe which is connected to the inner chamber. Access to each compartment is through risers (not shown). Solids are pumped from both chambers, periodically. A nitrification/denitrification process is designed into this system.

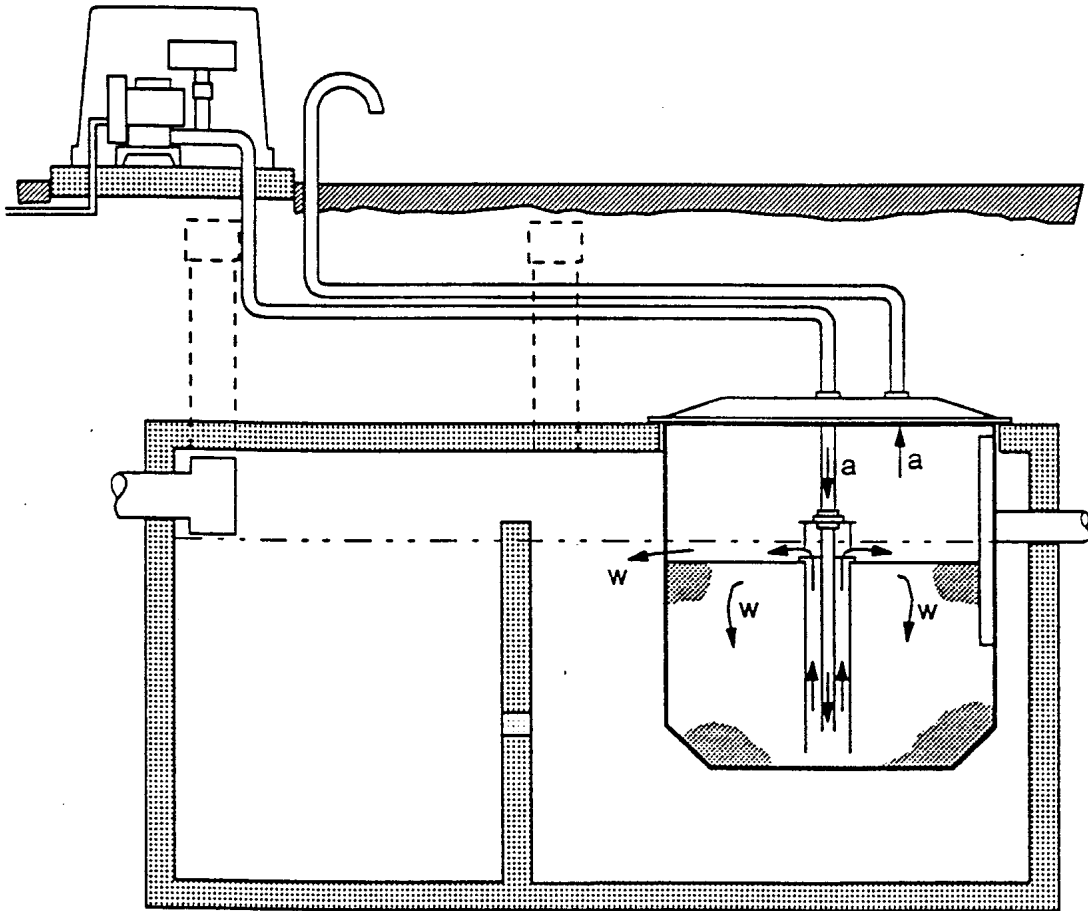

Fig. 9. Cross section of a Bio-Microbics FAST unit (Bio-Microbics).

c. MicrosepTec EnviroServer

The unit consists of a 5 compartment tank along with a thermal processor, blower(s), chlorinator and computer. This unit has an NSF Class 1 rating. It has been evaluated by the University of California - Riverside and has several accreditations by ANSI, SCC and RvD. Fig. 10 shows a cut-away view of the unit. The units come in 600, 1200 and 1500 gpd size.

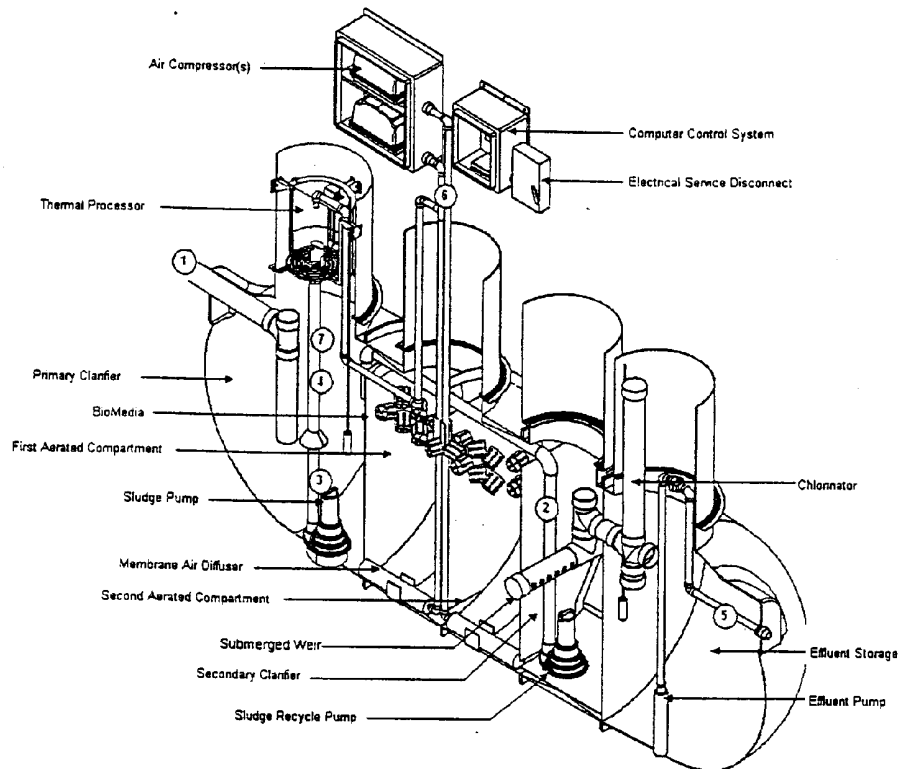

Fig. 10. Cut-away view of the EnvironServer Wastewater Treatment Unit (MicrosepTec).

The wastewater enters the primary clarifier where solids settle and the effluent and scum flow to the first aerated compartment with effluent movement into the second aeration compartment. Both of these compartments have floating media consisting of small cylinders with fins which serve as attachment sites for the bacteria. Air is delivered via a compressor and membrane air diffuser dedicated to each compartment. The small cylinders move around in the mixed liquor. There is about 15 cu. ft. of biomedica in each compartment for the 600 gpd unit. A single blower serves both compartments in the 600 gpd unit. The organic matter and suspended solids are reduced and the ammonia is converted to nitrate.

The mixed liquor flows through a submerged weir to the secondary clarifier chamber (compartment 4) where solids are settled out. A pump recycles the settled solids and effluent back to the primary clarifier where the nitrates are denitrified. In the 600 gpd unit

approximately 50 gph is recycled to the primary chamber with the pump controlled by a timer.

Effluent flows from the secondary clarifier through a chlorinator into the effluent storage unit where a pump discharges it from the unit.

A sludge pump, located in the primary clarifier and controlled by a timer, discharges accumulated solids, controlled by a timer, to a thermal processor where the effluent flows via gravity through a screen (1/16" opening) back into the primary clarifier. The screen retains solids. When the solids accumulate to a prescribed depth, the thermal processor reduces the solids to ash and gas using a 220 volt electric burner. The ash falls into the primary clarifier and the gas is scrubbed as it exits the processor.

A computer monitors the process and is connected to the Microseptec headquarters for 24 hr monitoring. Monitoring includes primary and secondary alarms, high water level, air compressor (pressure switch), disinfection (ORP sensor), thermal decomposition cycle (thermocouples) and sludge pump (temperature change). Regulators, via password, can access the monitoring.

d. The Nibbler and Nibbler Jr.

Nibbler: The Nibbler was developed to reduce the high strength wastes (restaurant and other) to BOD levels of typical residential septic tank effluent (Fig. 11). The high strength wastewater (grey water, not black waters) enters a septic tank/ grease trap before entering the Nibbler.

The Nibbler consists of a concrete tank with pods of buoyant media in the upper portion of the tank. The media serve as attachment surfaces for the bacteria. A settling zone exists in the lower portion of the tank. Air is introduced in the lower portion of the pods with the mixed liquor circulated through the media. A small blower located adjacent to the unit supplies the air.

The upper portion of the mixed liquor is aerobic while the lower portion is anaerobic. Facultative bacteria, operating under either aerobic or anaerobic conditions, exist in an intermediate zone. Treated effluent with lower BOD, TSS and FOG (fats, oils and greases) exits the unit.

Nibbler Jr.: The Nibbler Jr. was developed for residential use (Fig. 12) to renovate failing soil absorption units by significantly reducing the organic load to the failing system. The unit is designed to remove BOD and suspended solids but not to the same extent as expected of Class 1 units. The unit is placed in the second compartment of a double compartment tank. It is desired to have the opening in the clear zone between the tanks for the first compartment can provide surge capacity. The liquid level in both tanks moves up and down through out the day

as wastewater enters the first compartment and the effluent is slowly discharged from the system. The unit can be placed in a second tank but must have sufficient surge capacity.

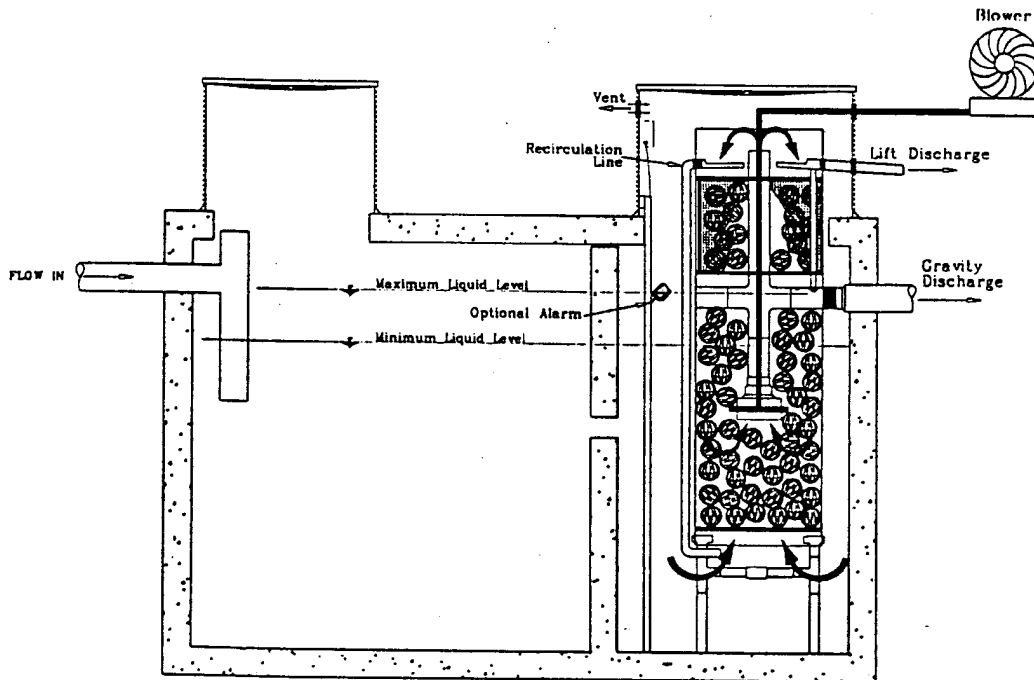
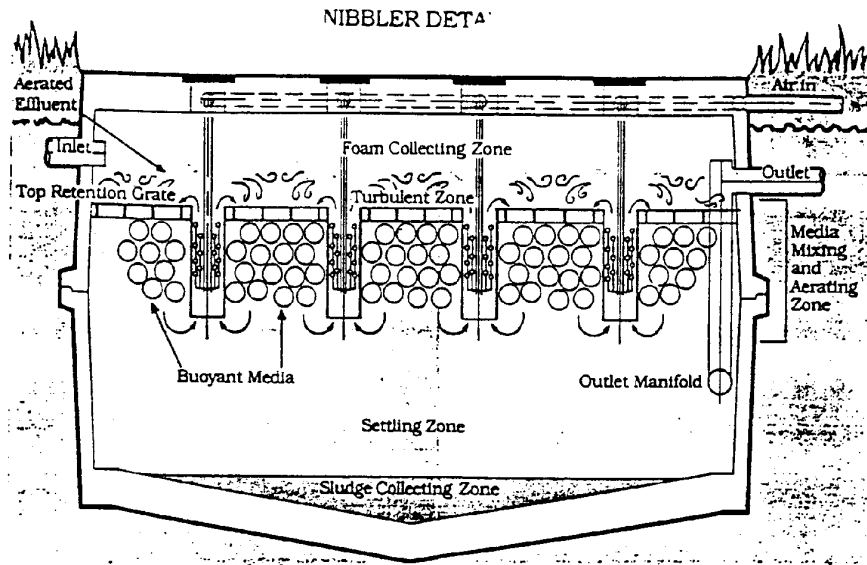

Fig 11. The Nibbler for high strength wastes. (NCS)

Fig. 12. Nibbler Jr. is placed in the second compartment of a two compartment tank. Effluent can discharge by gravity or be lifted (NCS).

Air is introduced near the bottom of the unit via an air lift tube using a regenerative blower located adjacent to the unit. The air lifts the wastewater upward between the inner and outer tube with a portion of the wastewater recycled to the bottom of the unit and a portion exiting the tank. The portion recycled and exiting the unit can be adjusted by changing the collection surface area, located in the splash zone.

This unit removes some nitrogen. Nitrogen reduction is enhanced by recycling a portion of the effluent to the bottom of the unit provided nitrates are present. This unit was not designed to specifically remove nitrogen.

e. Rotating Biological Contactor

A septic tank upstream removes the settleable solids. Effluent enters through the submerged inlet from an upstream septic tank (Fig. 13).

The disks rotate slowly with a portion of the disk submerged in the septic tank effluent. The biological growth is attached to the disks. During the submerged portion of the cycle, the

bacteria come in contact with the organic matter in the effluent and during the air exposed portion of the cycle, oxygen diffuses into the biological mat maintaining aerobic conditions.

Fig. 13. Schematic of a rotating biological contactor (CSM Rotodisk Inc.)

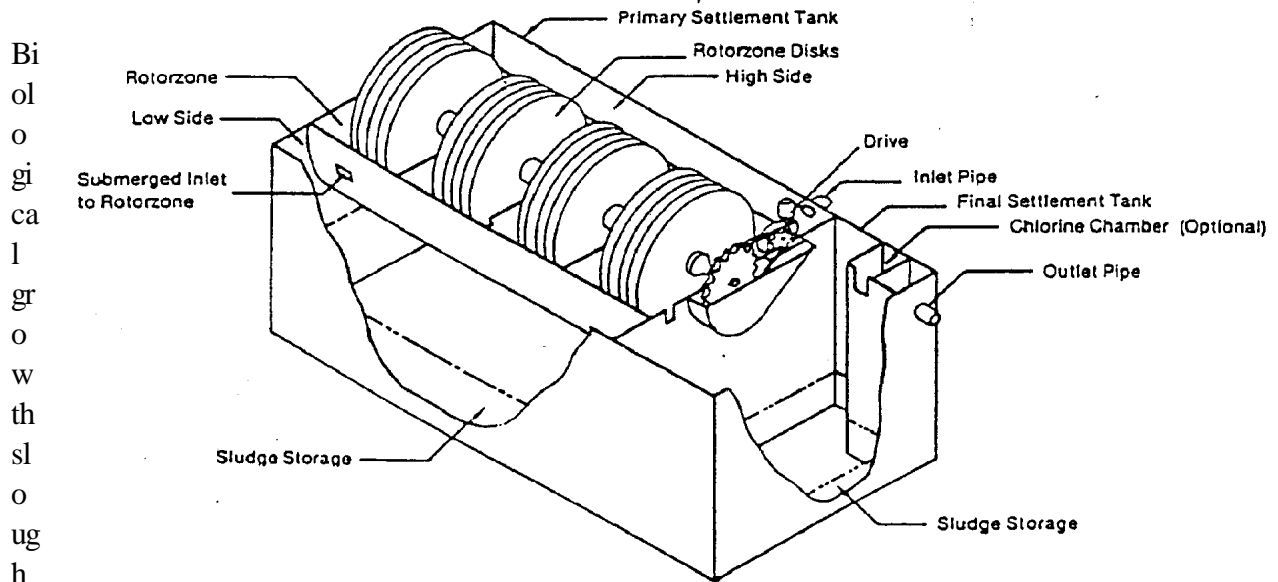

Bi
ol
o
gi
ca
l
gr
o
w
th
sl
o
ug
h
of

f the disks into the unit with solids recycled to the septic tank or removed from the unit. Pumping of solids is required periodically. Some nitrification/denitrification is likely in this process.

PACKED BED FILTERS (PBFs)

Packed bed filters, are also known as fixed film media units and trickling filters. The most popular packed bed filter, known primarily as an intermittent sand filter, dates back to the late 1800s where it was used to treat wastewater. Single pass sand filters and recirculating sand/gravel filters have been used for many years. More recently, peat filters and synthetic media filters have been developed. These units can operate as single pass filters (sand and peat) or as multiple pass (recirculating) filters. Aeration is achieved by air diffusing through the open voids in the media with oxygen diffusing into the cell mass attached to the media. Some units will use a small fan to assist air movement in and around the media. Bacteria and other microflora attach themselves to the media. As the wastewater trickles downward over the media, the bacteria extract the organic matter and utilize the dissolved oxygen from the wastewater.

System Characteristics

- Systems are either single or multiple pass (recirculation).
- All systems have a septic tank to settle out the large solids and scum.
- Oxygen is supplied via atmospheric diffusion into the voids between the media. Some units use a small fan to assist aeration.
- Bacteria attach themselves to the media.
- Physical, chemical and biological reactions take place as the effluent moves over the media and through some of the media (foam and textile). Solids are filtered out, organic matter is converted to carbon dioxide and water with new bacterial cells being generated but not to the same extent as in some aerobic units. Nitrogen is converted to nitrate.
- For the most part, packed bed filters are more tolerant, some more so than others, to upsets by overloading and toxic materials entering the units. However, they can be upset if some care is not exercised.
- Most systems are operated with timed dosing which requires some controls and surge capacity in the septic tank/pump chamber. Some systems allow gravity flow to the unit.
- All systems should have sensor and alarms especially if pumps are part of the system.
- The septic tank needs to be monitored for solids and scum accumulation and pumped when appropriate. Solids accumulation in the packed beds generally does not accumulate as rapidly as in aerobic units. Units, loaded very heavily, will accumulate solids more so than units less

heavily loaded.

- In single pass filters, nitrogen is converted to nitrates with some denitrification taking place on micro sites that are anoxic. In recirculating filters, all or a portion of the filter effluent is recycled to a recirculating tank that receives septic tank effluent or back through the septic tank. Some type of flow splitter diverts part of the effluent downstream for further processing or dispersal. Denitrification takes place in the recirculating tank if the anoxic conditions exist. Denitrification is enhanced if the filter effluent is recycled to the septic tank.
- These units need periodic maintenance by a professional. Some units may need monitoring every 6 months while others may require monitoring annually. Telemetry may reduce the number of site visits and will provide continuous monitoring.

Single Pass Units

a. Single Pass Sand Filter

The system consists of a septic tank/pump vault or septic tank followed by a pump chamber, followed by the sand filter. Converse (1999a) provides a detailed description of single pass sand filters. Fig. 14 shows a cross section of a sand filter where all the components can be purchased with assembly on the job site. The sand and gravel media is obtained locally.

There are other sand filter designs and variations. The sand and

Fig. 14. Cross section of a single pass sand filter showing an internal pump chamber. Units

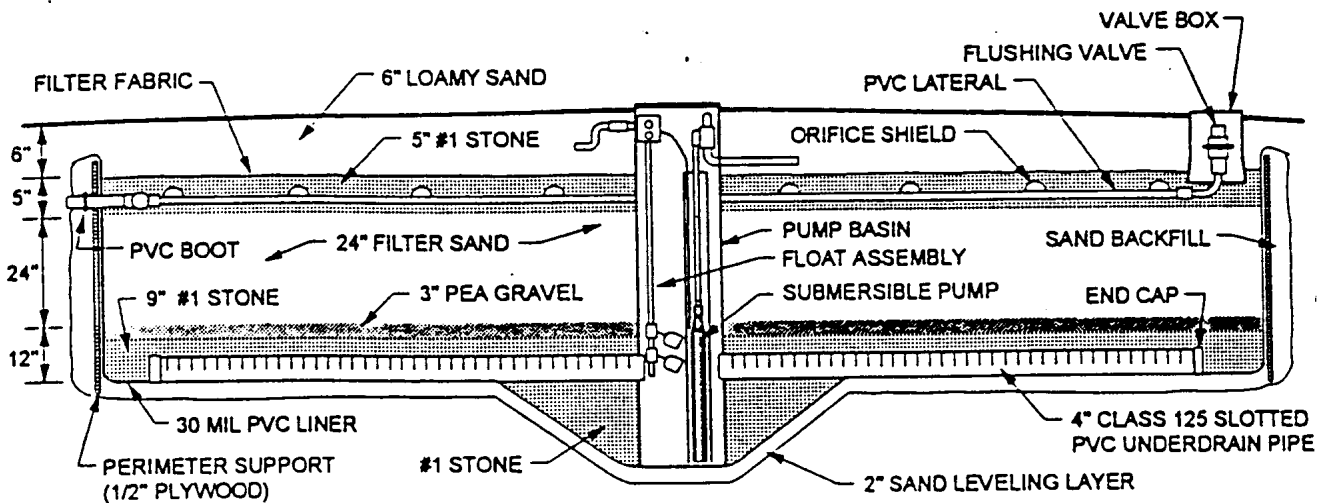

are available with gravity flow from the unit (Orenco).

gravel must meet a certain specification with the sand specification tied to a specific design loading rate. A typical unit for a 3 bedroom system would be 18 by 20 ft or 10 by 36 with a loading rate of 1.2 gpd/ft².

The effluent is timed dosed from the septic tank/pump vault through a distribution network located in the aggregate in the top of the filter. The distribution network consists of a series of 1/8" diameter orifices with each orifice serving 4 ft².

The effluent infiltrates into the sand where the bacteria are attached to the sand surfaces. Air diffuses into the aggregate and media from above. As the effluent percolates downward, the bacteria convert the organic matter to carbon dioxide and water. New cells are produced with old cells dying off and becoming food. Solids accumulation is minimal.

Organic nitrogen and ammonia are converted to nitrates. Some denitrification takes place in micro sites where oxygen may be limited but a discrete nitrification/ denitrification phase is not incorporated into the design.

The treated effluent is collected in the bottom of the lined filter where it flows to an internal pump chamber or it can flow by gravity to an outside receiver.

b. Ecoflo Peat Biofilter

This unit consists of a fiberglass shell with a filter bed of specially treated sphagnum peat moss. Fig. 15 shows a cut-away view of the filter. Septic tank effluent flows into a tipping tray located in the top center of the unit. The tray drops a predetermined volume of effluent onto a perforated plate where the effluent is distributed over the surface and infiltrates into the peat moss.

As the effluent slowly percolates downward, bacteria and other microflora convert the organic matter to carbon dioxide and water. New cells are produced and old cells die and are consumed by other microflora.

Treatment is via physical, chemical and biological interactions between the effluent and the media. Filtration, adsorption, ion exchange and microbial assimilation are some of the treatment mechanisms.

Effluent exits the bottom of the shell directly into larger aggregate layer sized to meet the infiltration requirements of the soil. On sites with soil and site restrictions, the unit can be placed on the soil surface with effluent pumped to the top of the unit. Provisions can be made to collect the effluent from the shell and direct it to a soil dispersal unit away from the unit. Where the effluent is collected, it can be recycled to the septic tank for denitrification of the effluent.

Air diffuses into the voids of the peat from above to allow for oxygen and gas exchange. The peat has a high absorption rate and retains moisture. The top of the unit must be exposed about 4-6" above grade to allow air to enter the system. The peat slowly decomposes and needs to be replaced every 10 years or so.

Due to the nature of the media, this system provides a suitable habitat for higher organisms such as protozoa and rotifers, worms and insects..

Organic nitrogen and ammonia are converted to nitrates. Some denitrification takes place in micro sites where oxygen may be limited but a discrete nitrification/ denitrification phase is not incorporated into the design.

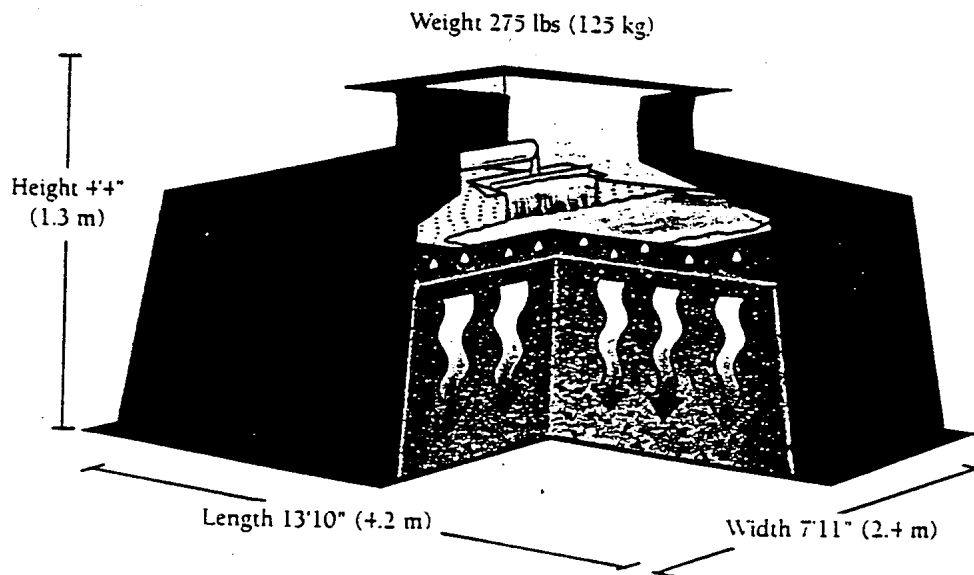

Fig. 15. Cut-away view of a peat biofilter (Ecoflo)

c. Puroflow Peat Filter

This unit consists of series of polyethylene modules containing peat biofibrous media with one module per bedroom served. Fig. 16 shows a view of the Puraflo Peat Biofilter. The septic tank effluent is pumped to the top of the unit where it is distributed over the surface of the biofibrous media.

Treatment is via physical, chemical and biological interactions between the effluent and the media. Filtration, adsorption, ion exchange and microbial assimilation are some of the treatment mechanisms.

The media supports higher life forms such as protozoans, rotifers, worms and insects which controls the bacterial population.

Effluent exits the bottom of the module directly into an enlarged aggregate layer sized to meet the infiltration requirements of the underlying soil. The unit can be placed on the soil surface with effluent pumped to the top of the unit. Provisions can be made to collect the effluent from the module and direct it to a soil dispersal unit away from the unit. Where the effluent is collected, it can be recycled to the septic tank for denitrification of the effluent.

Air diffuses into the voids of the peat from above to allow for oxygen and gas exchange. The peat has a high absorption rate and retains moisture. The top of the unit must be exposed about 4-6" above grade to allow air to enter the system. The peat slowly decomposes and needs to be replaced every 10 years or so.

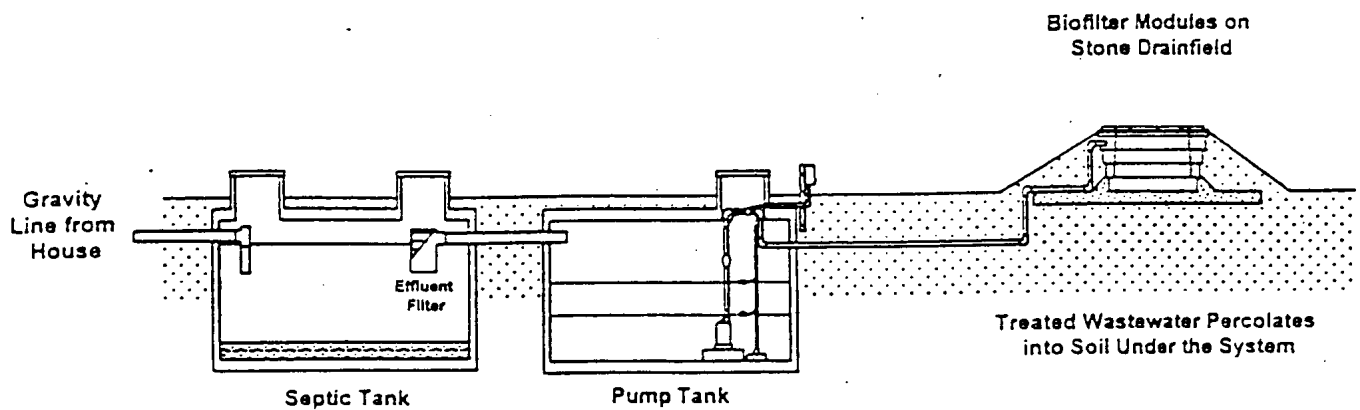

Organic nitrogen and ammonia are converted to nitrates. Some denitrification takes place in micro sites where oxygen may be limited but a discrete nitrification/ denitrification phase is not incorporated into the design.

Fig. 16. View of a peat biofilter (Puraflo).

Multiple Pass Filters (Recirculating Filters)

Multiple pass filters recycle the effluent several times through the media before it leaves the system. Obviously some of the effluent passes only once. The number of passes is dependent upon the recirculation ratio and the flow. Normally multiple pass filters can be loaded at a higher rate than single pass filters as there is another chance of treating the wastewater. Also, higher nitrogen removal rates can be obtained because the nitrified effluent can be returned upstream where there is normally more food and anoxic conditions present.

a. Recirculating sand/gravel filter.

Figure 17 shows a schematic of a recirculating sand/gravel filter and Fig. 18 shows a cross section of the filter. A number of design configurations exist. This particular unit can be purchased with all the components provided except for the media. The main difference between a sand and gravel filter is the size of the aggregate. Converse, (1999b), gives a more detailed description of various types of recirculating sand and gravel filters.

The septic tank effluent is conveyed to a recirculating chamber. A pump in this unit time doses the effluent to a sand filter at frequent intervals. The effluent enters the sand filter via a distribution network where it is distributed on the surface of the sand or gravel media. It infiltrates into the media and is treated as it percolates down through the media. Organic matter is converted to carbon dioxide and water. Pathogens are reduced.

Organic nitrogen and ammonia are converted to nitrates with some denitrification taking place at anoxic micro sites. The nitrified effluent flows back into the recirculating chamber where denitrification takes place because food is available and the conditions are anoxic. However, if the recirculating rate is too great, aerobic conditions may exist in the tank which will limit denitrification. Some designs will circulate the filter effluent to the inlet of the septic tank where more food and anoxic conditions are available.

Loading rates will vary depending on the media size with loading rates in the range of 3-5 gpd/ft² forward flow with 3-5 recirculations rates. Media size will vary with media in range of 1.2-2.5 mm with low uniformity coefficients to pea gravel size media. A 10 by 10 ft unit will serve a 3 bedroom home.

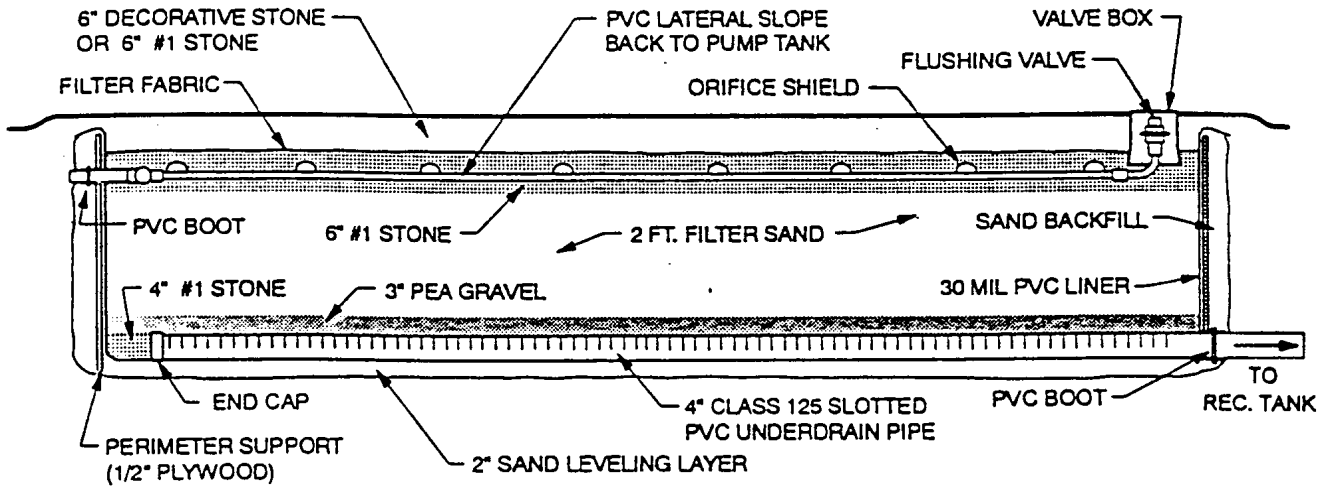

Fig. 17. Schematic of a recirculating sand/gravel filter.

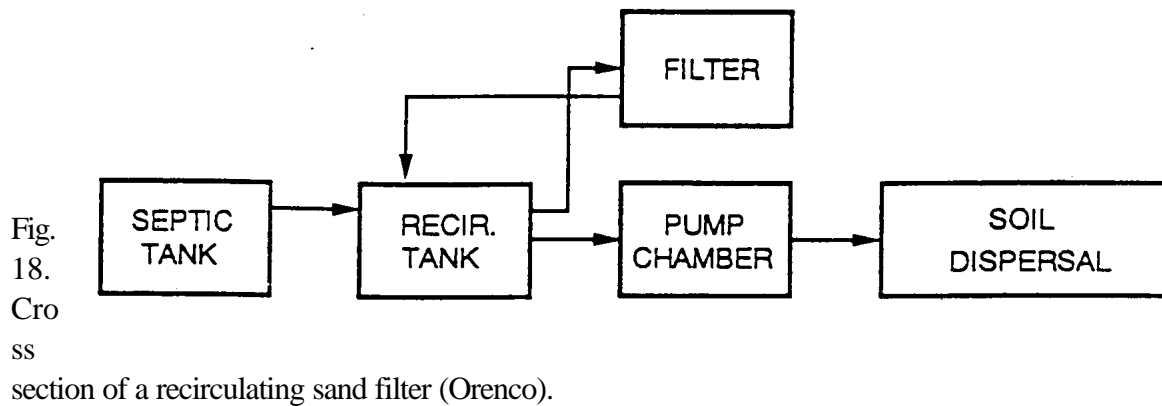

Fig. 18. Cross section of a recirculating sand filter (Orenco).

b. Split Bed Recirculating Sand Filter (Right System)

Figure 19 shows a schematic of a recirculating sand filter placed in concrete tanks. There are several similar units available elsewhere. The effluent enters the septic tank (2) where it flows to the sand filter dose tank (3). The effluent is sprayed over the surface of the elevated split bed sand filter with 60% of the effluent diverted to one section (4a) and 40% diverted to the other section (4b). The larger section has a coarse media while the smaller section has a finer media.

The organic matter is converted to carbon dioxide and water, pathogens are reduced and nitrogen is converted to nitrates. The effluent in section 4a returns to the inlet of the septic tank (2) where the nitrates are denitrified. The effluent from section 4b enters the pump chamber (6) where it is pumped to the soil dispersal unit. A timer doses the sand filter on a regular basis. When wastewater is not entering the septic tank, a valve directs effluent in chamber 6 back to chamber 3 to keep effluent circulating in the sand filter.

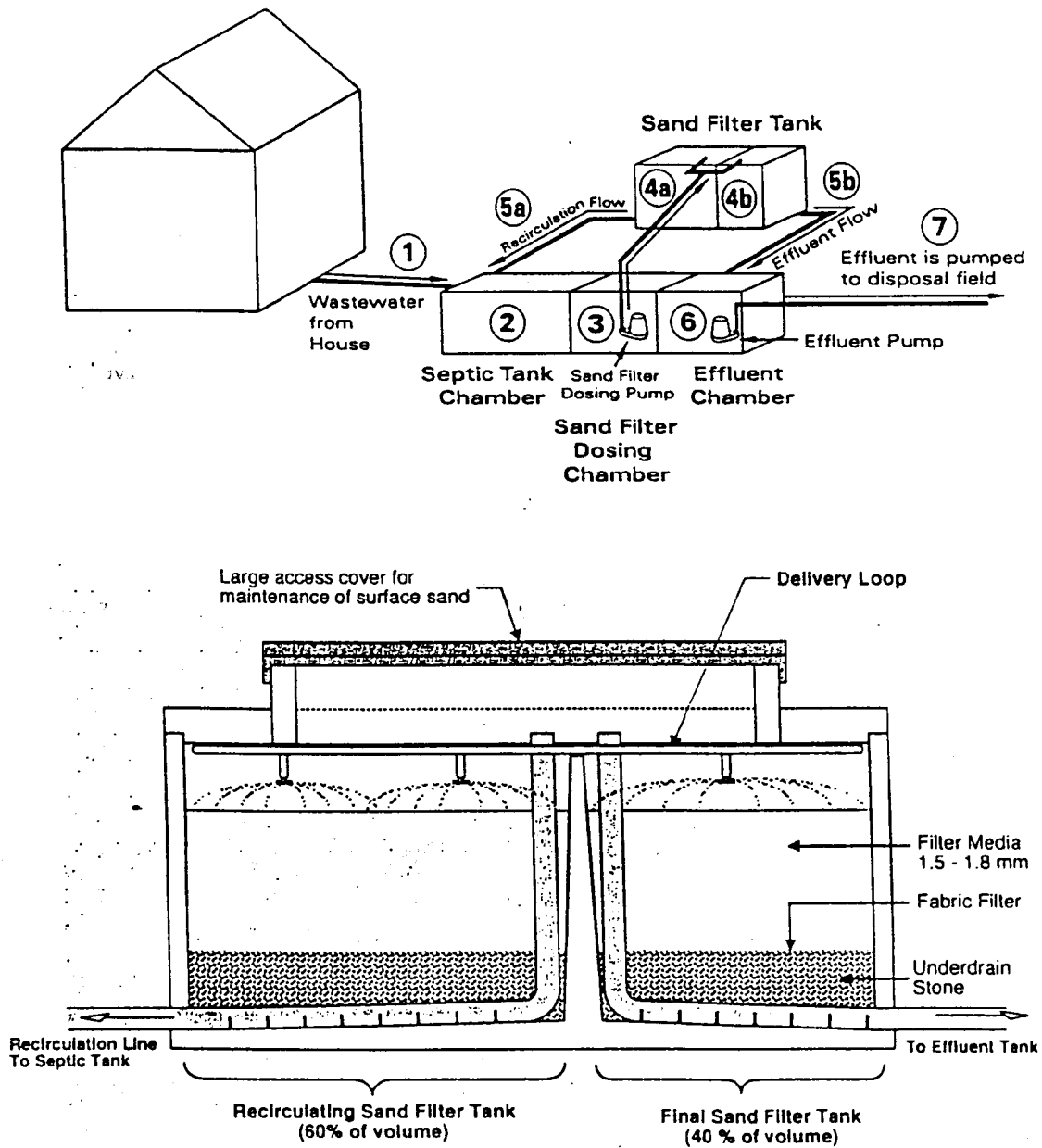

Fig. 19. Schematic and cross section of the split bed sand filter (Crest Precast)

c. AdvanTex Filter

AX Series: The AdvanTex AX Series filter consists of a primary chamber with a screened

pump vault located in the secondary chamber, a textile media filter, a flow splitter and a pump. The textile media filter with a surface area of 10 ft² and 30" high sits (for a 3 bedroom home) on top of the septic tank (Fig. 20).

The media in the filter consists of a series of hanging lightweight textile sheets that support microbial populations. The filter comes preassembled with minimal installation requirements. The unit can be loaded up to 50 gpd/ft² depending on wastewater strengths and other factors.

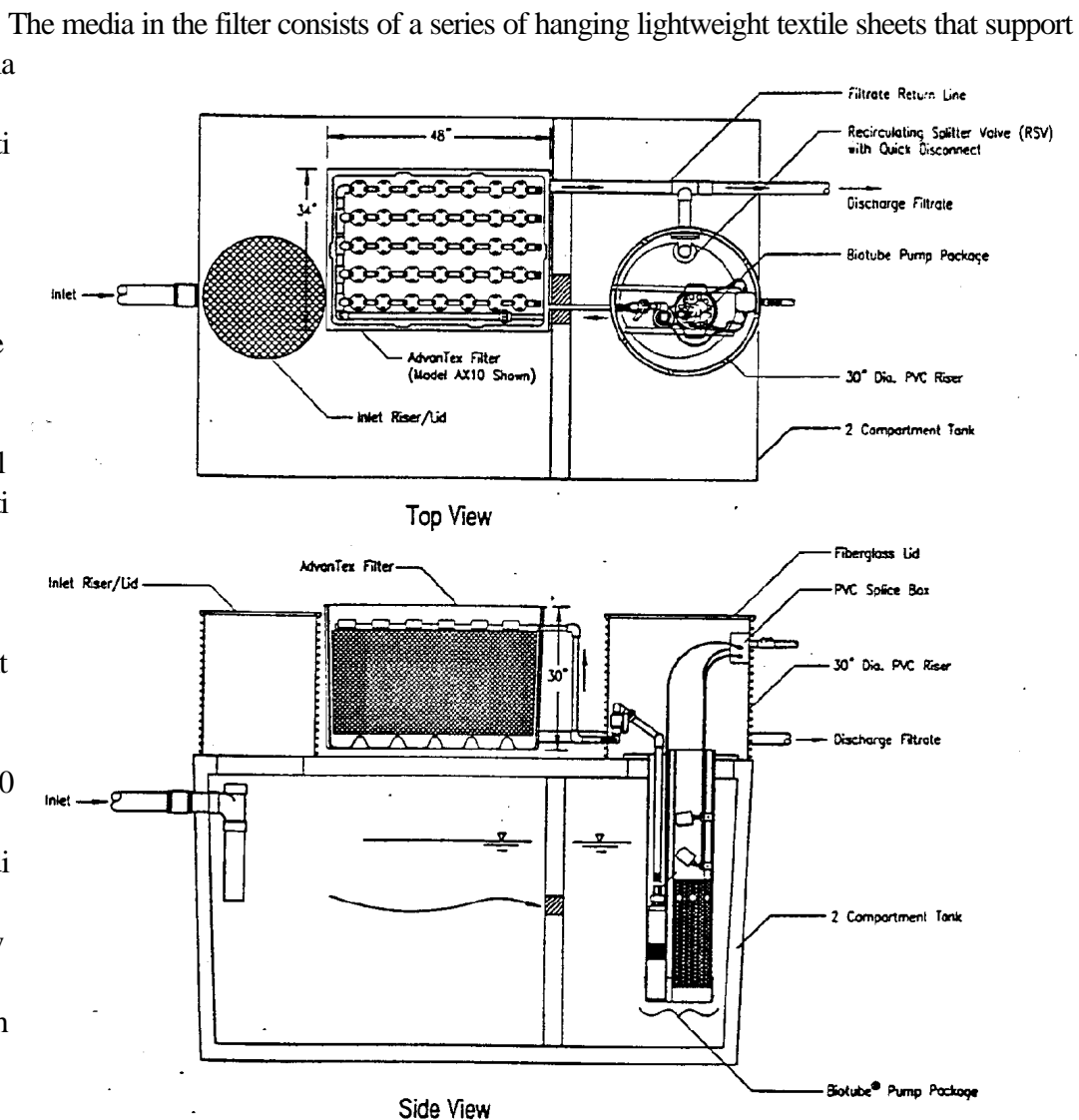

Fig. 20. A side view and top view of the AdvanTex AX series filter located in a two compartment tank with the pump assembly in the second compartment. (Orengo, Inc)

Household wastewater enters the primary chamber where solids settle out, with the effluent passing through an opening in the clear zone. A pump located in the screened vault of the secondary chamber sprays effluent on the filter surface where it percolates down through and on the surface of the textile sheets. The porous sheets offer very large surface area for bacterial attachment. The water holding capacity of the fiber is high. As the effluent passes through the media, the organic matter is reduced, pathogens are reduced and the ammonia is converted to nitrate by the bacteria attached to the media. Air enters via a gravity vent located in the top of the unit.

The nitrified effluent from the filter is returned to the first compartment of the septic tank. Since food is available and the contents are anoxic, the nitrates are denitrified. The effluent is recycled a number of times depending on the flow rate and liquid level in the primary and secondary chambers. A flow splitter diverts the effluent to the soil dispersal unit when the tank is full.

This unit can be monitored by telemetry.

RX Series: The AdvanTex RX series consists of a primary chamber, a screened pump vault located in a recirc/blend chamber, a textile media filter and a pump. The textile media filter, with a surface area of 30 ft² and 30" high (for a 3 bedroom home), sits adjacent to and above the primary chamber and recirc/blend chamber unit (Fig. 21).

The filter media consists of small lightweight textile coupons (chips) placed in horizontal layers that support microbial populations. The filter comes preassembled with minimal installation requirements. The unit can be loaded heavily up to 25 gpd/ft² depending on wastewater strengths and other factors.

Household wastewater enters the primary chamber where solids settle out with effluent passing through an opening in the clear zone. A pump located in the screened vault of the recirc/blend chamber sprays effluent on the filter surface where it percolates down and through the coupons. This unit can be operated in several modes depending on the desired effluent quality. In mode 1 and 2 the filter effluent is discharged to the recirc/blend chamber. In mode 1 the effluent passes through a flow splitter where a portion discharges to a downstream receiver and the rest returns to the chamber where it is recycled to the filter. In mode 2 all the filter effluent returns to the recirc/blend chamber with the blended effluent recycled to the filter. A portion of the blended flow is discharged through a solenoid valve when opened by a high water float. In modes 3 and 4 the effluent is returned to the inlet of the primary chamber. In mode 3 a portion of the filter effluent is discharged to a downstream receiver and the rest enters the primary chamber where it commingles with incoming wastewater. In mode 4 all the filter effluent enters the primary chamber where it commingles with the incoming wastewater. The mixed wastewater enters the recirc/blend chamber where it is pumped to the filter. A portion of the blended effluent discharges to the downstream receiver via a solenoid valve when opened by the high water float. Mode 4 allows for pressured distribution to the downstream receiver while mode 3 is gravity discharge. A small fan supplements air distribution to the coupons.

This unit can be monitored by telemetry.

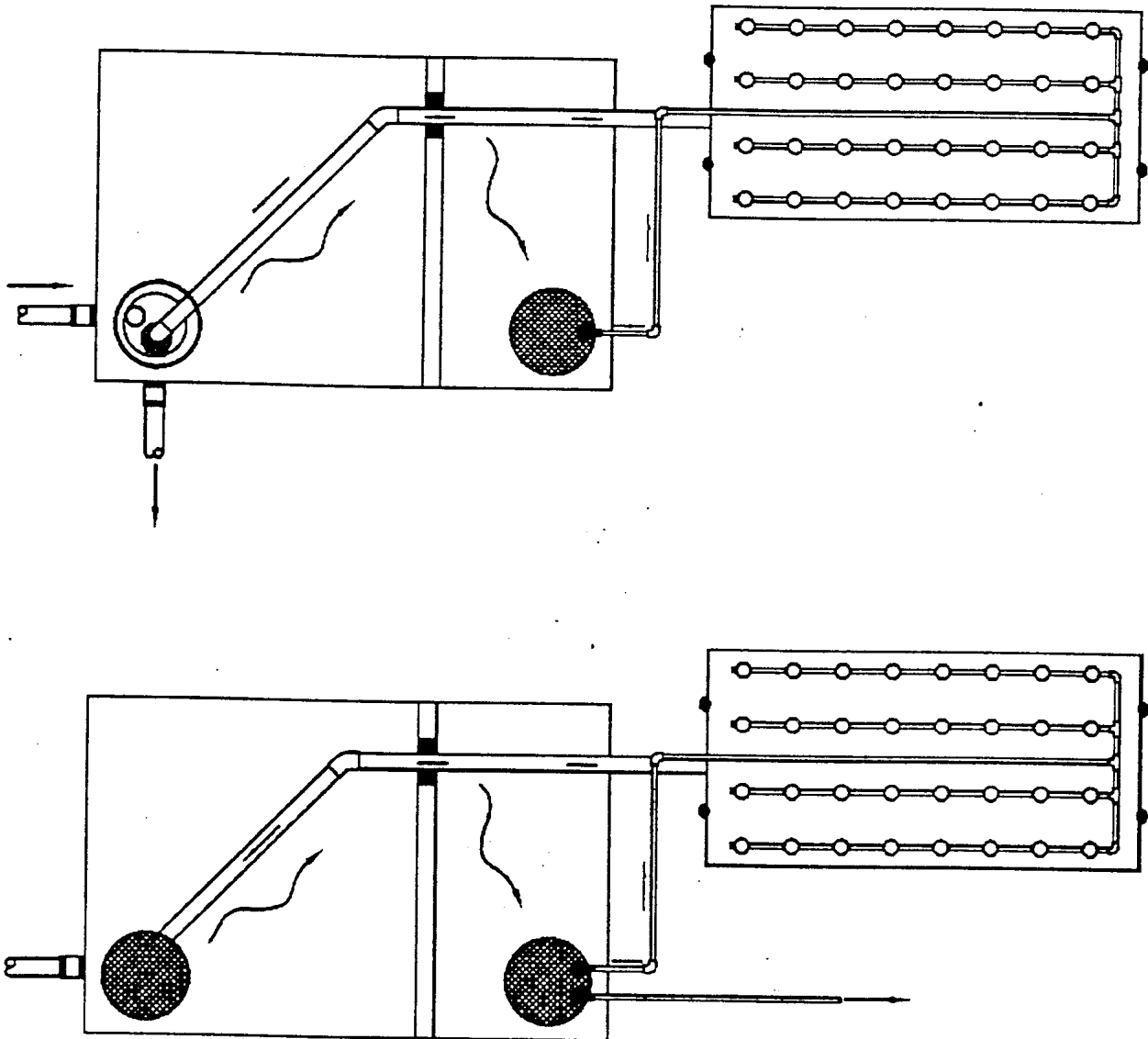

Fig. 21. Plan view of an AdvanTex RX series filter in Mode 3 (top) and Mode 4 (bottom). In Mode 1 and 2 filter effluent enters the recirc/blend chamber instead of the primary chamber. (Orenco).

d. Waterloo Biofilter

The Waterloo Biofilter is a fixed media aeration unit consisting of a septic tank, pump chamber and biofilter placed in a wooden building above ground or in a concrete container with cover below grade (Fig. 22).

Media consists of 2" foam plastic cubes (same material as used in seat cushions) placed at random in a pod. The pod consists of a cylinder basket made of semi-rigid netting material that is about 2 ft in diameter by 2 ft high. The pods are stacked two high.

A spray nozzle is located directly above each set of pods with effluent time dosed to the nozzle. A fine mist is applied over the entire top of the pod. Bacteria grow on the surface and inside the foam cubes. As the effluent moves downward, the effluent flows over the foam and into the foam cubes.

Air moves through and around the cubes to provide oxygen to the bacteria. A fan is mounted in the side of the unit to assist in air movement. The effluent exiting the unit flows to flow splitter where a portion of the effluent flows to the soil dispersal unit with the remainder flowing back to the septic tank or the pump chamber where denitrification takes place.

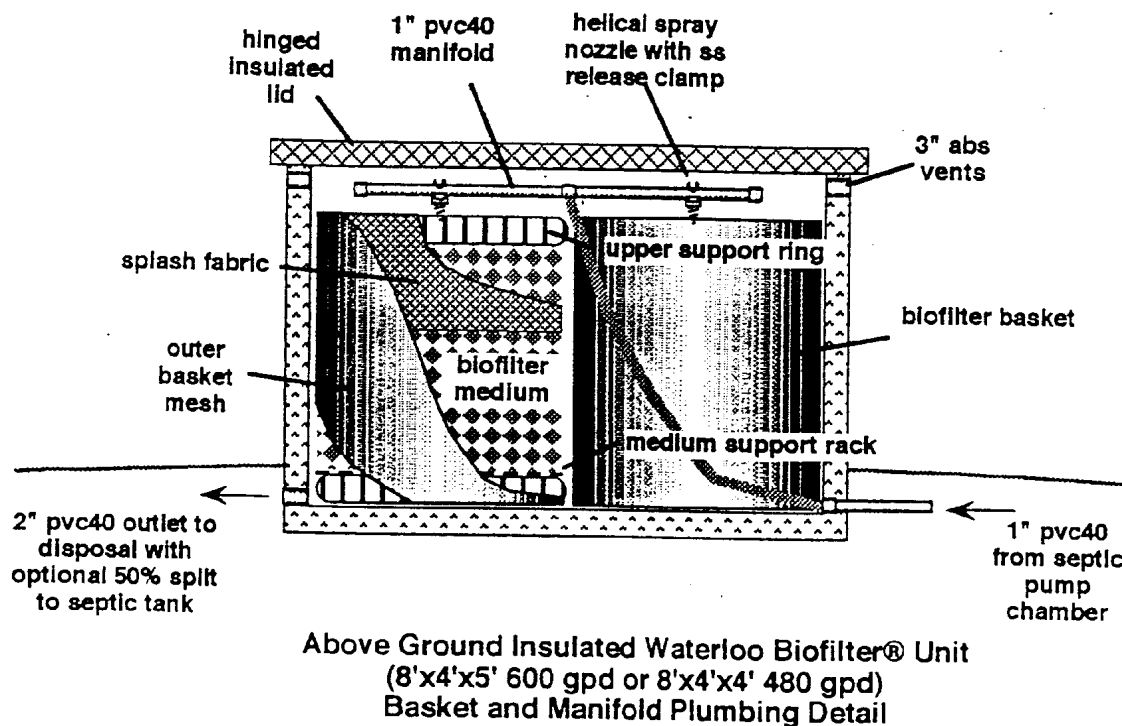
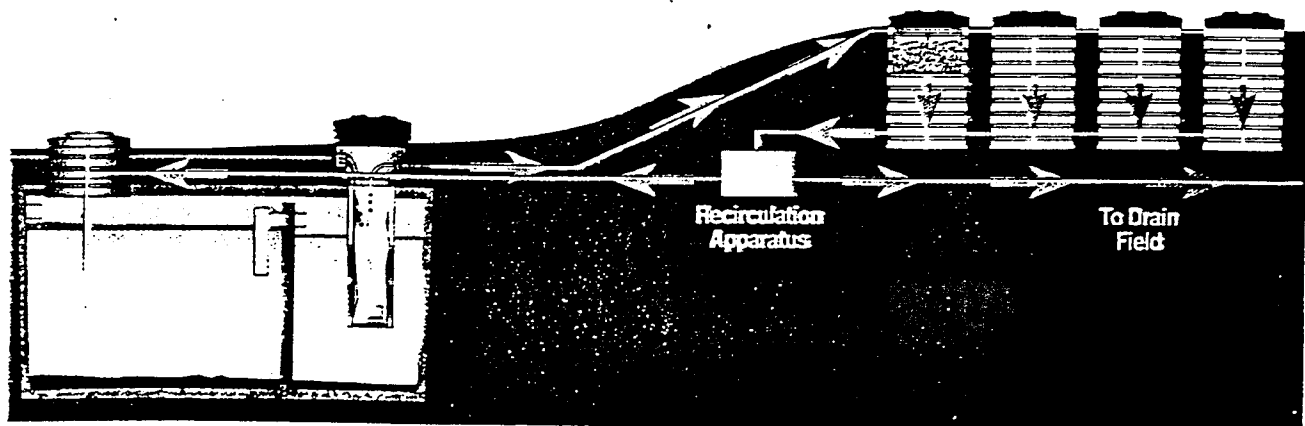

Fig. 22. Waterloo biofilter for on-site treating of wastewater. The system can also be installed below ground surface (Waterloo Biofilter Systems Inc.).

e. Aerocell Advanced Modular Treatment System

The Aerocell Advanced Modular Treatment System consists of a septic tank, pump chamber, aerocell treatment modules and a flow splitter (Fig. 23). It utilizes open-cell plastic foam as the treatment medium which is the same media as used in the Waterloo Biofilter. The unit comes in modules consisting of a plastic tank approximately 30" in diameter and 30" high. Four and 6 modules in parallel are required for a 3 and 4 bedroom homes, respectively. The filtered septic tank effluent is pumped to each pod where the effluent is sprayed on the surface.

The effluent passes over and through the media where the bacteria consume the organic matter and the nitrogen is converted to nitrate. The filter effluent passes to a flow splitter where a portion is recycled to the septic tank for denitrification and the remaining portion flows to a



pump chamber or drain field.

Fig. 23. View of a Aerocell advanced modular treatment unit (Zabel)

f. EnviroFilter System

This system incorporates a septic tank in series with the EnviroFilter Unit followed by a dispersal unit. A cross section of the treatment unit is shown in Fig. 24. The concrete container consists of a stack of 3 concrete sections. The upper two sections are media filters and the bottom unit is the recirculating unit. The three stacks are joined together with gaskets to make the unit water tight. The end section contains the pump and piping. Septic tank

effluent is introduced into the bottom section. The effluent is time dosed to each of the media filters where it is distributed over the surface of each media filter using a pressure distribution network. The effluent flows through the media into a collection pipe in the bottom of each filter. The collected effluent flows to the recirculating unit (bottom section) where it is mixed with the septic tank effluent. The mixed effluent is recycled to the media filters with some of the return effluent discharged out of the unit. As the effluent passes through the media filter, the organic matter (BOD/TSS) is reduced, ammonium is converted to nitrate and pathogens (fecal coliform

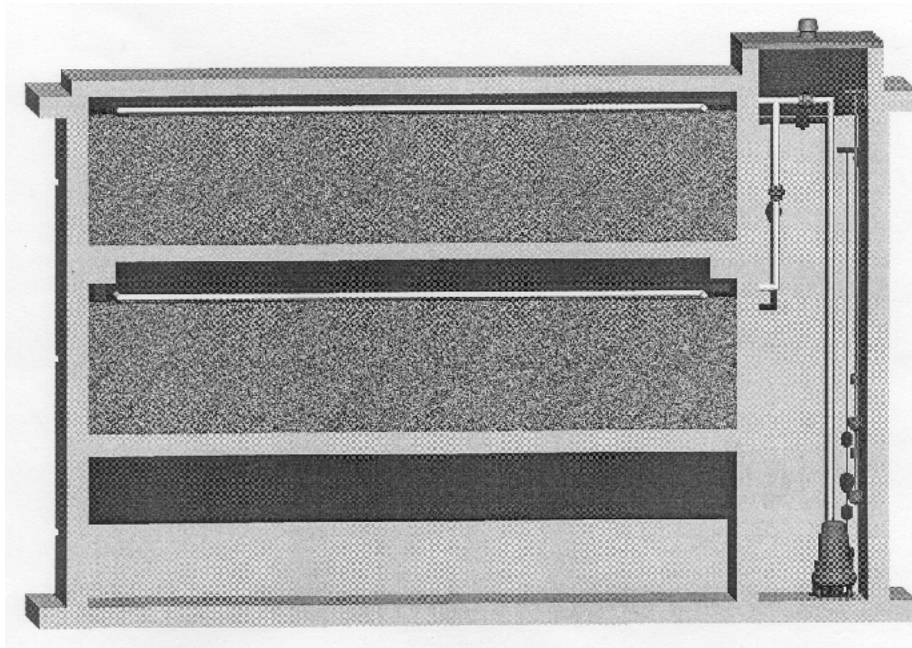

indicators) are reduced. As the nitrates reenter the recirculation chamber it mixes with the septic tank effluent which provides a carbon source and an anoxic environment for

denitrification which lowers the nitrogen concentration.

Fig. 24. Cross section of an EnviroFilter Unit. (Earthtek Environmental Systems Inc.)

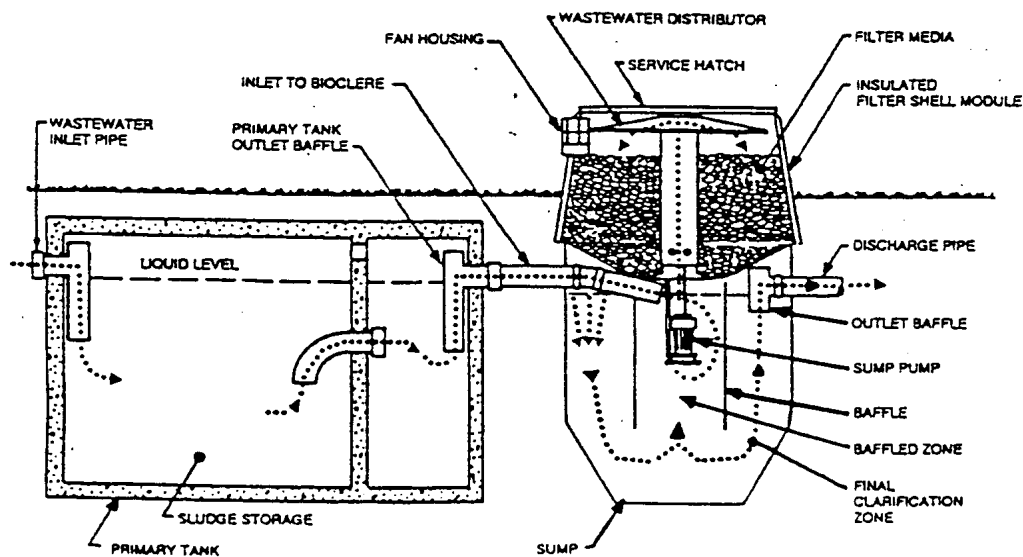

g.

**Biocle
re
Syste
m**

This
syste
m
incor
porat

es a septic tank upstream of the Bioclere unit (Fig. 24). This unit is NSF Class 1 rated and comes in 500 gpd capacity and larger units.

The septic tank effluent passes into the baffled zone in the sump of the unit. The effluent is pumped at timed intervals to the top of the trickling filter where it is distributed over the filter media. The media consists of randomly packed plastic media serving as attachment sites for the bacteria. As the wastewater passes over the media, the bacteria remove the organic material and convert the nitrogen to nitrates. Air diffuses into the media void area to provide aerobic conditions in the filter. A fan assists in the air movement.

The effluent reenters the sump where it is mixed with the sump contents. A portion of the effluent is recycled through the trickling filter, depending on the amount of septic effluent entering the unit. The solids that slough off the trickling filter settle out in the bottom of the sump. The nitrate is denitrified. Clarified effluent exits the unit through the discharge pipe.

Fig. 25. Cross section of a typical residential Bioclere system (Ekofinn Limited).

h. Others

There are many other aeration type devices on the market that serve in the same capacity as those listed above. It is not the intent of the author to discriminate against any one by not including their unit. More units will be added as time permits.

CRITERIA FOR SELECTING A PRETREATMENT/TREATMENT UNIT

There are basically two types of aeration systems available today for on-site and small community wastewater treatment as stated in this publication. They are basically the ATUs (aerobic units) and the packed bed filters (PBFs). Within each group there are a number of units. All of these units need to be managed by an on-site wastewater treatment professional who is knowledgeable of the technology. Without effective management, the systems will not function effectively and perform to expectation. How does one select a system from among a vast number of units? Reliable service is a predominant criteria used by many. The following criteria may be of help.

1. What is the level of pretreatment desired before the effluent is discharged to the dispersal area?

The two choices are either septic tank effluent (primary) or aerobically treated effluent (secondary). If the dispersal unit is a soil based system, then septic tank effluent is suitable if

the soil/site criteria are suitable. If soil/site criteria are limiting, then secondary treated effluent will need to be achieved to allow for downsizing of the soil system and a reduction in separation distance or soil credit.

If surface discharge is the dispersal unit, then secondary effluent is necessary with possible disinfection.

2. Is BOD/TSS removal an important criteria?

If so, most units will produce an effluent <25 mg/L if the unit is properly maintained. Some units will provide a more consistent removal rate than others. In most dispersal units, especially subsurface,, it doesn't really make any difference if the average or median value is 10 or 25 mg/L. Some units tout that their unit will produce <10 mg/L of BOD or TSS. The important point is will the system produce a good quality effluent on a consistent basis (75 -90% of the time). Is there a fail safe feature in the unit or will solids be carried over to the downstream unit if the unit becomes upset. Some units have fail-safe features while others do not.

3. Is nitrogen reduction an important criteria?

All properly operating units should convert most of the organic nitrogen and ammonium to nitrate. If they are overloaded organically, the effluent will have low BOD and TSS but high TKN (organic + ammonia) values. Most units will reduce nitrogen in the range of 20-30% but there are units that are specifically designed to remove 50-70% of the nitrogen through nitrification/denitrification. This is typically done by recycling some of the nitrified effluent back into the anaerobic portion of the unit or by the use of timers to shut the air supply off periodically and allow the contents to go anoxic.

4. Is fecal coliform removal an important criteria?

Not all units will remove similar amounts of fecal coliforms (indicator of pathogen removal). Consistency is also important as some units have a more consistent output than others. Unfortunately, most aeration systems are not rated on fecal removal and the data may be hard to obtain.

5. Is the level of maintenance required important?

Some units will require more inspection and maintenance once every 6 months while others may only need annual inspection and maintenance.

6. Is cost an important criteria?

There are three types of costs associated with on-site systems; initial costs, operating costs and maintenance costs. Annualized costs should be the cost that is used if cost is a factor. Some units may have a lower initial cost but the operating and /or maintenance costs are much higher. Some units require a blower/pump to run continuously while others have pumps that are intermittent.

REFERENCES

Federal Register. 1987. U.S. Congress, Washington, DC

NSF. 1996. Standard Number 40. Individual aerobic wastewater treatment plants. NSF International. 3475 Plymouth Road, P.O. Box 1468, Ann Arbor, MI 48106. (313-769-8010)

Converse, J.C.. 1999a. Single pass sand filters for on-site treatment of domestic wastes. Small Scale Waste Management Project. 345 King Hall, University of Wisconsin-Madison. 608-265-6595. [Http://www.wisc.edu/sswmp](http://www.wisc.edu/sswmp).

Converse, J.C.. 1999b. Recirculating sand/gravel filters for on-site treatment of domestic wastes. Small Scale Waste Management Project. 345 King Hall, University of Wisconsin-Madison. 608-265-6595. [Http://www.wisc.edu/sswmp](http://www.wisc.edu/sswmp).

LIST OF MANUFACTURERS REFERENCED IN TEXT

Bio-Microbics Inc., 8271 Melrose Drive, Lenexa, KS. 66214 (913-492-0707)

Clearstream Wastewater Systems, Inc. P.O. Box 705, Silsbee, TX 77656 (409-385-1395)

Consolidated Treatment Systems Inc. 1501 Commerce Center Drive, Franklin, OH. 45005
513-746-2727.

Crest Precast Inc. 609 Kistler Drive, LaCrescent, MN 55947. 1-877-843-4231.
www.RIGHTSystem.com

Cromaglass Corporation, P.O. Box 3215, Williamsport, PA 17701, (717-326-3396)

CMS Rotodisk Inc. 5266 General Rd. Unit 12, Mississauga, Ont. Canada L4W 1Z7.

Delta Environmental Products Inc. 8275 Florida Blvd, Denham Springs, LA 70727.
(800-219-9183)

Earthtec Environmental Systems Inc., Chaffee and Associates, Inc. 204 South St., bateville, In 470006.
(812-934-5035).

Ekofinn Limited, 33639 Ninth Ave. So. Federal Way, WA 98003 (206-661-6128)

Jet Inc., 750 Alpha Drive, Cleveland, OH 44143 (216-461-2000)

NCS, 16207 Meridian, P.O. Box 73399, Puyallup, WA (206-838-2359)

Norweco, Inc. 220 Republic Street, Norwalk, OH 44857-1196 (419-668-4471)

Orenco Systems Inc. 814 Airway Avenue, Sutherlin, Oregon. 97479-9012.
(1-800-348-9843). [Www.orenco.com](http://www.orenco.com)

Waterloo Biofilter Systems Inc. 2 Taggart Court, Unit # 4 Guelph, Ontario, N1H 6H8, Canada.
(519-836-3380)

Zabel Environmental Technology, 10409 Watterson Tr. Louisville, KY40299-3701. (1-800-221-5742). [Http://www.zabel.com](http://www.zabel.com).

